



INSTRUCTION MANUAL

CAPACITANCE TYPE LEVEL SENSORS

MODEL : TSD

Meanings of indications for safety used in this Instruction Manual are as follows.



WARNING: Indicates that improper handling assumes the risk of a fatal or serious injury.



CAUTION: Indicates that improper handling assumes the risk of injury or damage to property only.

TOWA SEIDEN INDUSTRIAL CO., LTD.

HEAD OFFICE Phone: 81-6-6340-5522, Fax: 81-6-6340-5519

OSAKA PLANT Phone: 81-6-6340-2831, Fax: 81-6-6349-6551

URL <http://www.towa-seiden.co.jp>

No.ETSD1000-1

2019. 8. 30

Introduction

1. This instruction manual explains how to use and adjust the product properly. Please be sure to read this manual before using the product. Keep this manual in a convenient location for easy reference as required.
2. This instruction manual describes the standard specifications. If the product you purchased is based on special specifications, the details may differ from the product.
3. The instructions in this manual are subject to change without prior notice.
4. If you have any questions or notice any errors in this manual, please contact our sales representatives.
5. We may modify the product to improve product quality. In the event of such modifications, we may sometimes offer alternative parts rather than original parts or an alternate product to our customers. For more details, please contact our sales representatives.

Safety indications used in this instruction manual have the following meanings.



Warning: This means that improper handling of the product may lead to death or serious injury.



Caution: This means that improper handling of the product may result in personal injury or damage to property or equipment.

Table of Contents

Introduction	1
1. Precautions on Handling the Product	2
2. Product Outlines	2
3. General Specifications	3
4. Outline Drawings	3
5. Type Description Table	4
6. Precautions on Mounting	5
7. Wiring	8
8. Panel Description	10
9. Adjusting Sensitivity	11
10. Initial Setting Procedure	12
11. Setting Delay Timer	14
12. Troubleshooting	15
13. Maintenance	16

1. Precautions on Handling the Product



Warning This product has no explosion-proof structure. Do not use the product in a place where flammable or explosive gas is generated.

- 1) Check the identification plate after unpacking to confirm that the product is what you ordered. In the event the product is not what you ordered, please contact us.
- 2) Check the product for any damage. In the event of any damage, please contact us. Damage may be due to an accident during transportation.
- 3) Do not apply excessive force the product. Impacts from dropping or tipping the product may cause damage.
- 4) Do not place any object on the product. Doing so may create excessive force on the product leading to damage.
- 5) When applying paint to the product, if paint is applied on the identification plate, information on the plate will be covered by the paint, hindering maintenance.
- 6) Do not use or store the product in a corrosive atmosphere (such as NH_3 , SO_2 , and Cl_2). Corrosive gas may penetrate the product, causing corrosion or damage to internal parts.
- 7) Avoid using or storing the product in a place where large vibration exists. In the event of exposure, remove the source of the vibration or prevent the vibration from being transmitted to the product.

2. Product Outlines

2.1 Product objectives

This product is a sensor for measuring liquids, powder, grains, and slurry in a tank or hopper at the level where the detector is mounted by means of the static capacitance (C) of the measuring instrument.

2.2 Operation Principle

A static-capacitance type level sensor is composed of electrodes (a ground electrode and detection electrode) and electronic circuits, with the electrodes constituting a capacitor. With the ground electrode contacting a tank, a capacitor including the tank is formed. Conditions such as shape, dimensions, layout, and peripheral situations determine the capacitance of the capacitor. If conditions other than the specific permittivity (*1) of the measured objects are the same, the capacitance of the capacitor depends on the specific permittivity of the measured objects. If we take the capacitance for air as a reference, we can distinguish the difference in capacitance created by measured objects with different values of specific permittivity. In addition, by taking either one of the two measured objects with different specific permittivity as a reference, we can distinguish the two objects. This product detects the static capacitance of measured objects and outputs signals.

*1 Specific permittivity is the ratio of the static capacitance of a capacitor where an insulating substance (dielectric) fills the space between its electrodes to the capacitance of the capacitor where a vacuum exists between its electrodes with the dielectric removed. Specific permittivity is a constant depending on the types of materials.

3. Specifications

Power supply voltage	24V DC \pm 10%
Power consumption	1.5 W
Output	Relay output (1C contact) 250V AC 3A (Resistance load) 30V DC 3A (Resistance load)
Sensitivity	High sensitivity 0.5 to 10 pF General sensitivity 2 to 20 pF Low sensitivity 5 to 100 pF Very low sensitivity 20 pF or more (Sensitivity is changed with a DIP switch at initial setting)
Operation display	Red LED
Timer function	On-delay Timer time 0 to approx. 10 seconds (variable)
Operating ambient temperature	-10 to +60°C
Protecting structure	Housing: IP – 65 equivalent
Material of case	Aluminum die cast ADC12

4. Outline drawing

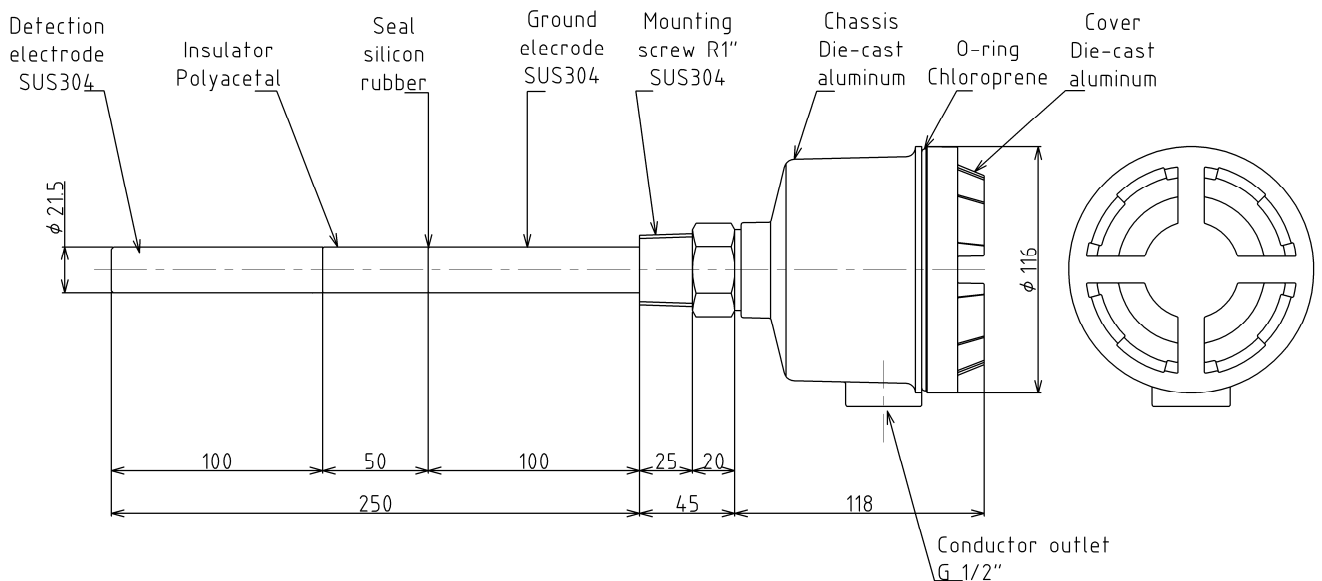

Standard outline dimensions

Individual dimensional outline drawings are provided separately.
Please contact our sales representatives.

5. Type Description Table

TS□ - □□□ - □□□

*L dimension column is blank for flat types

L dimension	
025	L - 250mm
200	L - 2000mm
A00	L - 10m

Amplifier specifications		
A	All-in-one standard amplifier	AC 100/200 V -10% - +20%
D	All-in-one standard amplifier	DC 24 V ±10%
F	Others	

Temperature inside the tank	
A	80°C max.
B	150°C max.
C	200°C max.
D	Special heat-resistance

Mounting		
1	Threaded mounting	R 1"
2	Threaded mounting	R 3/4"
3	Slide screw type mounting	R 1"
4	Standard flange mounting	5K65A aluminum
5	Ferrule mounting	2S
6	Threaded mounting with other sizes	
7	All slide type mounting with other sizes (including the flange type)	
8	Flange mounting with other sizes and materials	
9	Ferrule mounting with other sizes	

Electrode		
S A	Standard rod-type electrode	
WA	Standard wire electrode	wire diameter ϕ 5 mm
WB	Standard wire electrode	wire diameter ϕ 8 mm
X A	Standard flat electrode	
F A	Rod-type electrode	Teflon coated
S Z	Special rod-type electrode	
G A	Load-bearing rod-type electrode	
W Z	Special wire electrode	
X Z	Special flat electrode	
F Z	Special coated electrode	
G Z	Special load-bearing rod-type electrode	

6. Precautions on Mounting

6.1 Checking detector mounting

- 1) In mounting the detector, secure space for mounting and an area for maintenance around the periphery of the tank to maintain workability. The space must be secured after mounting the detector, taking subsequent maintenance into consideration. (Space corresponding to at least the total length of the product is required.)
- 2) When mounting the detector using a short pipe, be sure to have the ground electrode protrude from the inner wall of the tank by 10 mm or more.
- 3) When using detectors placed side by side, mount the detectors apart at a distance of 250 mm or more.
- 4) Mount the detection electrode at a distance of 100 mm or more from the tank wall.
- 5) Mount a wire-type electrode at a position where the electrode does not touch the inner wall or a stay of the tank due to swinging of the wire or electrode upon input or output of the measured object.

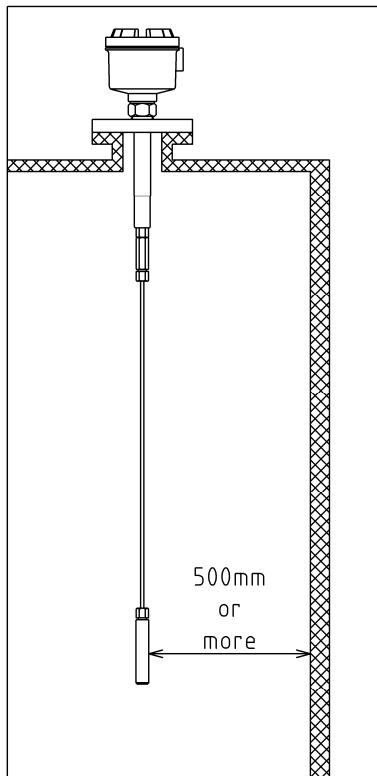

Mount the wire electrode at a position where it does not touch the inner wall due to its swinging.

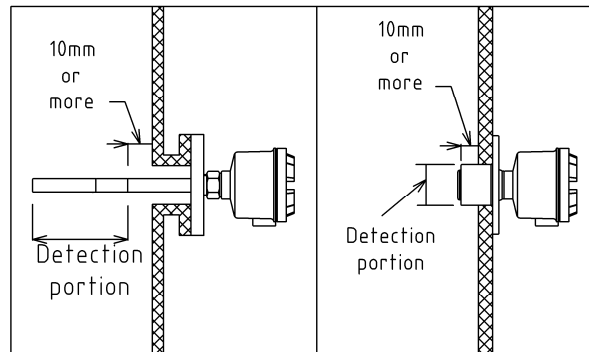

Mount the sensor ground electrode in such a way that it protrudes from the tank inner wall(or nozzle) by 10 mm or more.

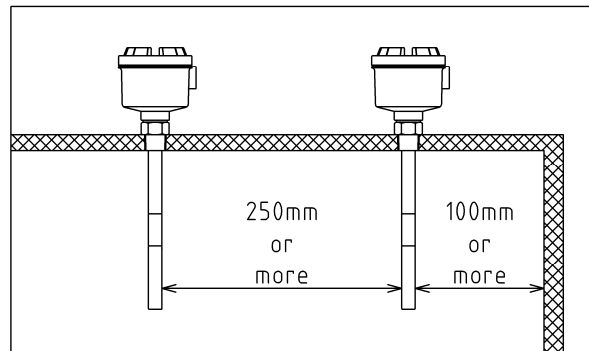

When using electrodes placed side by side, mount one electrode at a distance of 250 mm or more from the other. Mount the electrode at a distance of 100mm or more from the tank wall.

Caution: Failure to meet these conditions may result in abnormal use due to adhesion of the measured object to the electrode, deterioration of sensitivity, and inability to make adjustments.

- 6) When mounting the product onto a tank, be sure to establish electrical conductivity between the ground electrode (flange and mounting screw portion) and the tank. In the case of a non-metallic tank, establish a grounding wire to ground the ground electrode (Class D grounding work, 100 Ω or less). In establishing a grounding wire, use the

amplifier panel plate, which is electrically conductive to the ground electrode or one of the screws that secure the terminal block.

- 7) Avoid mounting the product near the motor, pump, or inverter that generates noise or an ultrasonic cleaner or a transceiver that generates high-frequency electrical fields. Failure to do so may cause the product to malfunction.
- 8) In detection of powder and grains, pay attention to the angle of repose. Do not mount the detector in a position where powder does not move around the detector due to the angle of repose. Doing so may cause the product to malfunction.
- 9) Pay attention to dead stock. Do not mount the detector in a place where powder remains creating dead stock. Doing so may cause the product to malfunction.
- 10) In detecting powder or grains, mount the detector in a place where no bridge is created. Creation of a bridge may cause the detector to malfunction and damage the sensor when the bridge collapses.
- 11) Do not mount the detector in a place where a lump may hit the detector directly. Failure not to do so may cause the product to malfunction and damage the detection unit of the sensor. Protect the detection unit with a guard plate, as required. In establishing a guard plate, place it at a distance of 100 mm or more from the detection electrode.
- 12) Do not mount the product in a place where it is exposed to vibration or impact. Mounting the product close to a vibrator or an air knocker may damage or cause the product to malfunction .
- 13) When mounting the product in a place where the temperature may rise, be sure to observe the allowable temperature range for the electrode (inside the tank) and the allowable temperature range for the instrument (60°C). Failure to do so may cause the product to malfunction.
- 14) Do not mount the product in a place where it is exposed to direct sunlight. When the temperature exceeds the allowable range for the instrument, it may cause a malfunction. Provide a protective cover as required.
- 15) Take the precautions described below when using the product in a place where the housing may be exposed to water drops (such as rain water). The housing of the product is provided with jet water protection (IP65 equivalent) for water intrusion. However, inadequate tightening of the cover or improper handling of the conductor outlet may allow water to enter, causing a malfunction or damage to the product. Be

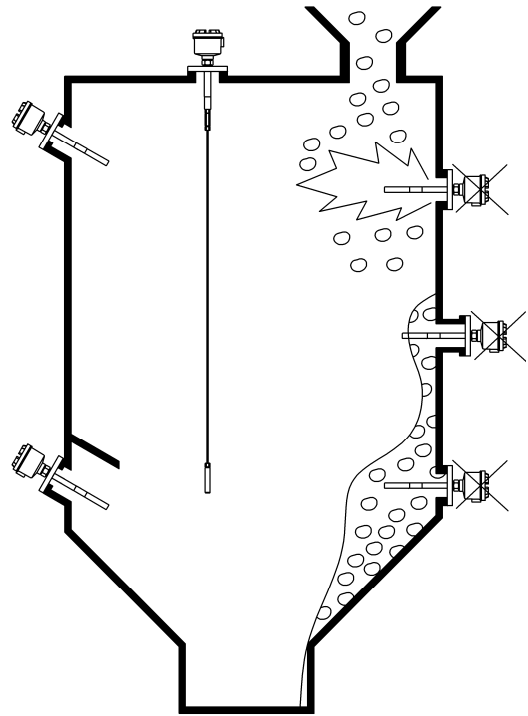

sure to handle each portion properly.

- 16) When mounting the detector in a horizontal position, be sure that the conductor outlet is oriented downward.

6.2 How to mount the product



Caution Do not try to screw in or take out the detector by holding the chassis. The housing may come apart causing damage.

- 1) In the case of a threaded mounting, secure the product by applying force to its hexagonal portion with the appropriate tool. Provide sealing processing, as required, when pressure is generated inside the tank. Do not try to screw in or take out the product by holding the chassis. The housing may come apart causing damage.
- 2) In the case of a flange mounting, check that nominal designations for the companion flange at the tank match those for the flange of the product. If the check result is in order, put the gasket in-between and secure the product with a bolt conforming to the standards using the appropriate tool. Bolts and gaskets are not attached to the product. Please contact our sales representatives as required.

6.3 Product mounting orientation

- 1) In the case of a horizontal (transverse) mounting, the electrode is parallel to the measured object, providing a larger electrode area to for detection. This generates a greater change in capacitance even with a small change in the measured object, providing high-accuracy detection. However, if the measured object is an adherent, the stability of detection may deteriorate. Mounting electrodes downward will reduce accumulation and adhesion of the measured object.
- 2) In the case of a vertical (longitudinal) mounting, adhesion of the measured object to the electrode is less likely, providing stable operation. However, the part of electrode that is effective for detecting the measured object becomes smaller, resulting in reduced accuracy. For detection of the lower limit of a tank, the lengthened electrode is a disadvantage.

For conductive material, when both the detection and the ground electrodes contact the measuring object, malfunctions may occur due to resistance compensation function, considering that detection is executed only by the detection electrode. To cope with this problem, first try to adjust the sensitivity. If this does not solve the problem, coat the electrode with insulating material.

7 Wiring

7.1 Precautions on wiring



Warning When implementing wiring, be sure that the supply power sources and power sources applied to the output are shut off. Failure to do so may result in danger of electric shock, electric leaks, and short circuits or combustion.



Warning Do not connect 100V/200V. This may lead to breakage or personal accident.



Warning Please do the wiring of 0-24V correctly.



Caution Do not connect a load that exceeds the ratings for the relay contacts. This may cause damage or deterioration of the relay contacts. In the case where load capacity exceeds the ratings for contacts, install a relay that meets the load capacity between the load and the output terminal of the product. Do not connect the relay output terminal with only the power source involved. Do not connect the power supply directly to the relay output terminal without connecting a load. Doing so may cause a short circuit or damage the product.

7.2 Wiring procedure

- 1) Remove the cover to make sure the connections to each terminal are correct before starting the wiring. The terminals use M3 screws. Be sure to use a screwdriver compatible with the screws. For crimp terminals, use one with the size equivalent to R2 – 3. Cable with an outer diameter of $\phi 6 - 12$ mm is recommended.
- 2) For the cable, use a cable gland or wire tube compatible with the size of the conductor outlet (G1/2") for the cable to run through.
- 3) Do the wirings of 0-24V properly with attention to polar.
- 4) No-voltage contact output is provided by a relay. With terminal c shared, terminals c and a are open in a no-detection status and conducting in a detection status, whereas terminals c and b are conducting in a no-detection status and open in a detection status.
- 5) After finishing the wiring, be sure to attach the cover. Be sure that the cover is tightly mounted by screws.

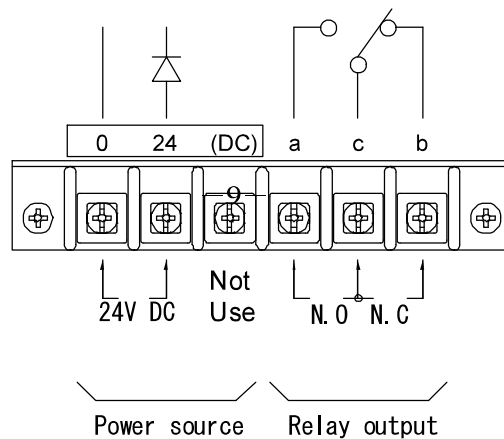

Terminal alignment and wiring diagram

7.3 Conductor outlet

The cable runs through the conductor outlet of the product and is secured either with a cable gland or with the cable tube that is connected to the housing. In either case, be sure to prevent water running along the cable or cable tube from directly entering the housing by configuring the connection of the cable and flexible tube downward first and then upward. Improperly securing the cable with a cable gland or inadequate connection of the cable tube may allow foreign material, such as dust and dirt, to enter the housing or it may allow water to penetrate, resulting in malfunction of the product. Be sure to mount the conductor outlet in the downward direction.

8. Panel Description

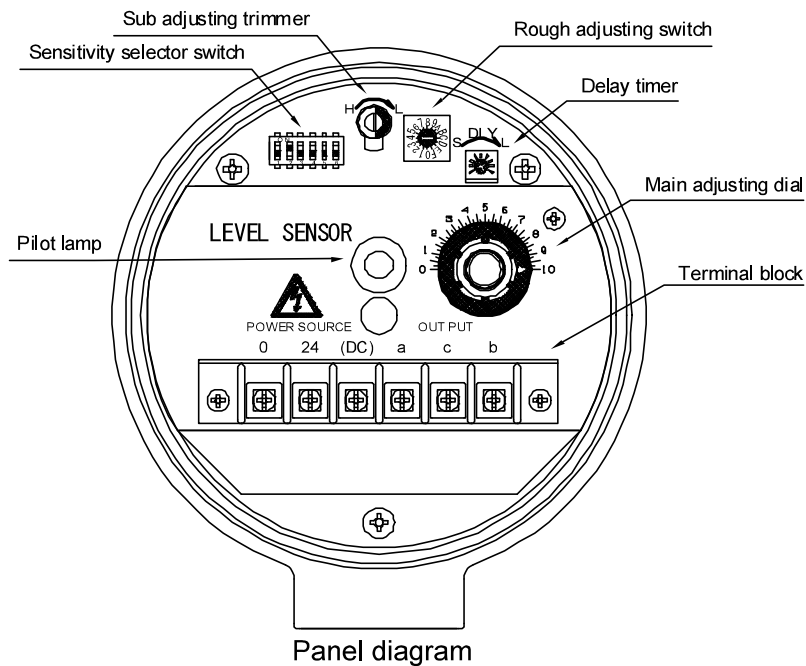

<Description of each unit>

- Main adjusting dial

This dial is used to adjust the sensitivity according to the measuring objects. The effective range of adjustment is "0 - 10" in scale with a half-turn of the dial. The dial itself rotates without limit.

- Auxiliary adjustment trimmer (set by default)

This is used during the initial setting of the main adjusting dial. The effective range of adjustment is a half-turn from the horizontal position of the minus slot (the brown face up and silver face down), but there is no limit on the rotation.

- Coarse adjustment switch (set by default)

This switch is used when the adjustment exceeds the range covered by the auxiliary adjustment trimmer. The switch turns in either direction, but at the initial setting, set the switch to turn clockwise.

- Sensitivity selection switch (usually, the default is the general sensitivity setting)

Sensitivity can be selected according to the measuring objects. For the method of selection, refer to 10 "Initial Setting Procedure" on page 12.

- Pilot lamp (color in red)

The lamp turns on upon detection.

- Delay timer

Time from detection to output can vary between 0 and 10 seconds. The effective adjustment range and rotation range is about 120° from S to L.

- Terminal block

Terminals for the power supply and relay output.

9. Adjusting Sensitivity

Use the main adjusting dial to adjust the sensitivity according to the property of the measuring objects before using the product.

After finishing sensor mounting and wiring, follow the procedure below to adjust sensitivity.

Adjust sensitivity under actual measurement conditions when possible.

9.1 Checking the maximum adjustment position

Check this value when the tank is empty (no measuring object exists in the electrode portion). Switch the power on and turn the main adjusting dial between “7.5 and 9.5” until the pilot lamp turns on. This position corresponds to the maximum value of the adjustment range. The value is set to “8.0” by default but the set value may vary depending on the mounting conditions. For resetting the value outside the range shown above, refer to section 10 “Initial Setting Procedure” on page 12.

9.2 Checking the minimum adjustment position

Check this value when the tank is filled with the measuring object up to the measuring position. Be sure the electrode is buried in the measuring object. Check that the pilot lamp has turned on. Turn the main adjusting dial to lower the value until the pilot lamp turns off. This position corresponds to the minimum value of the adjustment range.

If the pilot lamp does not turn off after the main adjustment dial reaches “0,” then set the minimum value to “0.” The minimum position varies depending on the property of the measuring objects and the sensitivity category. Check the value every time the measuring object or sensitivity category changes.

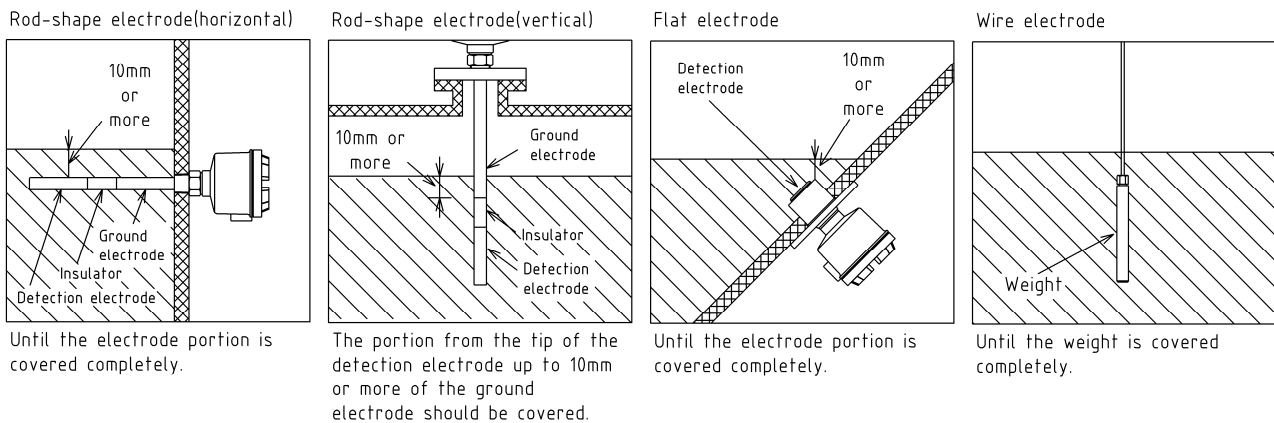

9.3 Determining the adjustment position

The middle point between the two scale values checked in 1 and 2 described above is the sensitivity adjustment position. Turn the main adjusting dial to the sensitivity adjusting position to finish the procedure. Do not move the adjustment position up or down more than necessary. Doing so may cause the product to malfunction. Confirm that the range of scale position checked at 1

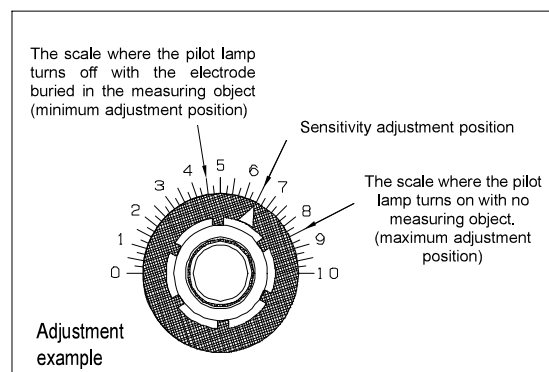

and 2 described above exceeds the 1 scale.
 If the range is 1 scale or less, the operation may be unstable, and the product cannot be used.

10. Initial Setting Procedure (Read this section if initial settings are required.)

The product settings have been configured at the factory as the default. The initial setting is required in the following cases:

- The maximum adjustment position has shifted significantly due to mounting circumstances.
- The amplifier has been replaced with another that had been in use in another place or with another electrode shape.
- Changes in the sensitivity category are required due to changes in the measuring objects or other factors.
- The sensitivity category does not match the measuring object.
- Electrode dimensions have changed. (Such as wire length)
- Others

 **Warning** The initial setting is performed with the power on. Pay special attention to avoid touching the terminals. Touching terminals may cause electric shock or short circuits.

Caution: In the adjustment, pay attention to avoid applying excess stress on each part.

Make sure the tank is empty (no measuring object exists in the electrode portion). You cannot make the adjustment if a measuring object exists in the tank. Keep the power turned on. Pay attention to on-off operations of output that occur several times during adjustment.

- 1) Setting the sensitivity category: The product provides four sensitivity categories: General sensitivity, high sensitivity, low sensitivity, and ultra-low sensitivity. Use the sensitivity selection switch to select a category.

General sensitivity: Turn only "2" and "6" on.

SW1	SW2	SW3	SW4	SW5	SW6
OFF	ON	OFF	OFF	OFF	ON

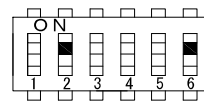

High sensitivity: Turn only "1" on.

SW1	SW2	SW3	SW4	SW5	SW6
ON	OFF	OFF	OFF	OFF	OFF

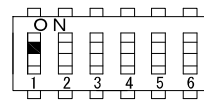

Low sensitivity: Turn only "3" and "6" on.

SW1	SW2	SW3	SW4	SW5	SW6
OFF	OFF	ON	OFF	OFF	ON

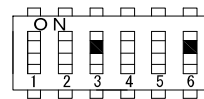

Ultra-low sensitivity: Turn only "4," "5," and "6" on.

SW1	SW2	SW3	SW4	SW5	SW6
OFF	OFF	OFF	ON	ON	ON

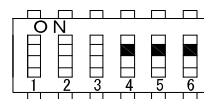

Sensitivity selection switch

About the rod-type electrode that the length is up to 200mm.
When you use it, turn on "5" of the sensitivity selection switch.

General sensitivity: Turn only "2" "5," and "6" on.

SW1	SW2	SW3	SW4	SW5	SW6
OFF	ON	OFF	OFF	ON	ON

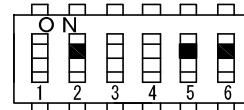

High sensitivity: Turn only "1" "5," on.

SW1	SW2	SW3	SW4	SW5	SW6
ON	OFF	OFF	OFF	ON	OFF

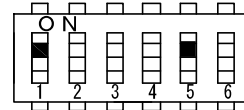

Low sensitivity: Turn only "3" "5," and "6" on.

SW1	SW2	SW3	SW4	SW5	SW6
OFF	OFF	ON	OFF	ON	ON

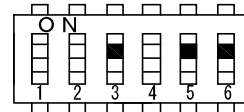

Ultra-low sensitivity: Turn only "4," "5," and "6" or

SW1	SW2	SW3	SW4	SW5	SW6
OFF	OFF	OFF	ON	ON	ON

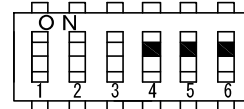

Sensitivity selection switch



Caution The product may malfunction, if you turn off "5" of the sensitivity selection switch on the rod-type electrode that the length is up to 200mm.

2) Adjust the main adjusting dial to the position on the scale at "8.5." This position is the maximum value of the adjustment range.

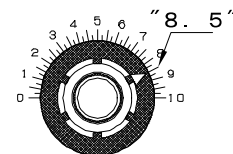

Main adjusting dial

3) Adjust the brown face of the auxiliary adjustment trimmer to the "H" side and the silver face (soldered face) to the "L" side.

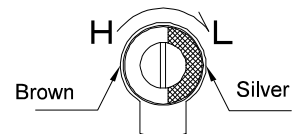

Auxiliary adjustment trimmer

4) Return the coarse adjustment switch once to "0." If the pilot lamp turns off in this situation, move to the next procedure. If the pilot lamp turns on, increase the number one at a time. Find the position where the pilot lamp changes from on to off. At this point, adjust the switch to the number where the pilot lamp turns off.

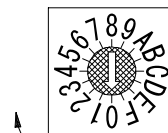

Coarse adjustment switch

5) Turn the auxiliary adjustment trimmer slowly toward the “H” side until it reaches the position where the pilot lamp changes from off to on. If the pilot lamp does not turn on after turning the trimmer up by a half-turn (the position where the brown face and silver face are inverted), move to the next step.

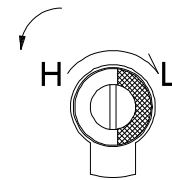

Auxiliary adjustment trimmer

6) Return the auxiliary adjustment trimmer to the status described in (3). Turn the coarse adjustment switch slowly counterclockwise to reduce the scale number by one. The pilot lamp will turn on. Next, turn the auxiliary adjustment trimmer slowly to the “L” side until the pilot lamp turns off. Then, turn the trimmer slowly toward the “H” side until it reaches the position where the pilot lamp changes from off to on.

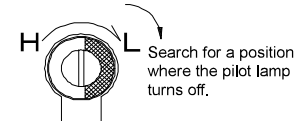

Auxiliary adjustment trimmer

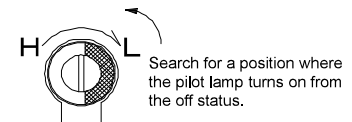

Auxiliary adjustment trimmer

7) Reduce the scale number of the main adjusting dial and check that the pilot lamp turns off before it reaches “8.0.”

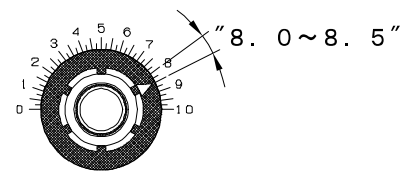

Main adjusting dial

This completes the initial setting procedure. Implement the sensitivity adjustment according to section 9 “How to Adjust Sensitivity” on page 11 before using the product.

11. Setting Delay Timer

This product provides a delay in time between detection of the measuring object and output operation. Turning the trimmer of the delay timer in the direction of “L” increases the delay time up to 10 seconds maximum for adjustment. The trimmer has stop positions in the S and L directions. Do not turn the trimmer past these positions. Doing so may cause damage.

Rotation range

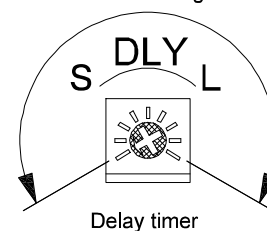

Delay timer

12. Troubleshooting

12.1 Trouble in adjustment

- 1) In checking the maximum adjustment position, the pilot lamp does not turn on for the main adjusting dial scales between “7.5 and 9.5.”
---Check that the power supply is on and the power supply side is properly wired.
- 2) In checking the maximum adjustment position, the pilot lamp remains turned on and does not turn off.
---Check that any stay exists close to the electrode.
---Check for condensation.
- 3) In checking the minimum adjustment position, the minimum position does not become stabilized.
---Check that the tank and the electrode are properly grounded.
---Check that the electrode is properly buried in the measuring object.
- 4) In checking the minimum adjustment position, the range between the maximum value and the minimum value does not exceed 1 scale.
---Check the situation by raising the sensitivity category.
---Check whether precautions on mounting the electrode were properly observed; the distance of the electrode from the tank wall should be 100 mm or more, and the protrusion of the ground electrode from the short tube nozzle should be 10 mm or more.
- 5) Detection works but no output is obtained.
---Check whether wiring on the output side is properly implemented.

12.2 Trouble during use

- 1) The product does not detect that the measured object has exceeded the measuring position.
---Confirm the angle of repose and check for a bridge.
---Check whether the sensitivity adjustment position is too low for use.
- 2) The product detects that the measured object has exceeded the measuring position even though the object is actually still under the measuring position.
---Check whether the sensitivity adjustment position is too high for use.
- 3) The level of the measured object has reduced below the measuring position but the detection status is not released.
---Check for residual measured object such as dead stock.
- 4) Detection performance does not stabilize.
---Check the vicinity for noise sources such as a motor, pump, or inverter.
- 5) The product is frozen in the detection status.
---Check for adhesion of the measured object to the electrode portion.
---Check for condensation inside the chassis and the electrode.
- 6) The product stopped outputting signals or is frozen in the output status.
---Check the contact resistance between the output terminals. (The normal value is 1 Ω or less.)

If check actions described above do not improve the problem, please contact our sales representatives.

13. Maintenance

 **Warning** In implementing maintenance and inspections, be sure to shut off the power supply and the power to the output except for checking the operations. Failure to do so may result in danger of electric shock, electric leaks, and short circuits or combustion.

Check point	Check period	Check item	Action	Check method
Electrode	Weekly	Check for adhesion of the measured object	Cleaning	Visual
	Monthly	Check for parts displacement, cracks, and deformation	Repair Parts replacement	Visual
	Every 6 months	Without Amplifier, check that the insulation resistance between the detection electrode and the ground electrode is 10 MΩ or more.	Repair Parts replacement	DC 500 V Insulation-resistance meter
Chassis	Weekly	Check that the cover has been tightly fixed.	Tightening	Visual and touching
	Weekly	Check for intrusion of dirt, water, dust and other objects.	Cleaning Actions against intrusion paths	Visual
	Monthly	Check for corrosion, condensation, and deformation.	Repair Parts replacement Check of use environment	Visual
	Monthly	Check the O-ring for cracks or deterioration.	Parts replacement	Visual
Amplifier	Monthly	Check for loosened screws.	Additional tightening	Screw driver
	Every 6 months	Check that the insulation resistance between each external terminal(except 0,24 terminal) and the chassis is 10MΩ or more.	Amplifier replacement	DC500V Insulation-resistance meter
Operation	Monthly	Turn on the power and check that the pilot lamp turns on and output switching is operating when the screw at the center of amplifier board is touched with a metallic object such as a screwdriver.	Amplifier replacement	Screw driver and others Tester